

# 多级真空发生器 Universal Pump

## TVMP10~60 Series



### Features(产品特点)

- Medium vacuum levels to -90 kPa
- Operates at 3.4bar
- Good for handling porous materials or if leakage is present
- Energy-Saving(ES)available
- Available with connection plate in aluminium(AD)and composite PPS(D)
- Supplies with a push-in connector for compressed air,through-flow silencer and mounting brackets
- 中等真空度达到 -90 kPa
- 在3.4bar的情况下运行
- 适用于多孔材料或有泄漏的情况
- 节能系统(ES)
- 铝连接板(AD)和聚苯硫醚复合材料连接板(D)
- 提供压缩空气接口所需的快速接头, 直流消声器和安装支架

### Specification(技术规格)

Air Supply Pressure Max(最大供气压力)	bar	7
Air Supply Pressure(opt)(最佳供气压力)	bar	3.4
Noise Level(噪音)	dBA	60~65
Temperature Range(温度范围)	°C	-20~80
Weight(重量)	g	750~1200
Material(材料)		AL, PPS, SS, PA, NBR

### Technical Parameters(产品参数)

Model (型号)	Max.Vacuum Level (最大真空度) (-kPa)	Max.Vacuum Flow (最大真空流量) (l/min)	Air Consumption (空气消耗量) l/min)	Weight(PPS Materials) (重量(PPS材料)) g	Min Tube Inner Φ (within 2m) (最小软管内径 Φ(2m内))		
					Air supply (供气)	Vacuum (真空)	Exhaust (排气)
TVMP10	92	420	116-185	675	>4	>12	>12
TVMP20		700	230-370	675	>6	>15	>15
TVMP30		950	365-610	837	>8	>19	>22
TVMP40		1010	445-720	837	>8	>19	>22
TVMP50		1400	545-780	1075	>10	>25	>32
TVMP60		1500	655-810	1075	>10	>25	>32

### How To Order(订购码)

TVMP10 - D - N - A - ES  
 ①            ②            ③            ④            ⑤

① Model(型号)

TVMP10 TVMP40  
 TVMP20 TVMP50  
 TVMP30 TVMP60

③ Sealing (密封件)

N	Standard (NBR) (标准(丁腈橡胶))
V	VITON (氟橡胶)
E	EPDM (三元乙丙橡胶)

② Connection Plate(连接板)

④ Non-Return Valve (止回阀)

A	Yes
-	No

⑤ Control Device(控制装置)

PD	Electric Air Supply(电控供气)	PVD	Electric Control(Air Supply+Vacuum Breaking)Combination(电控(供气+破坏真空)组合)
PQ	Pneumatic Air Supply(气控供气)	PVQ	Pneumatic Control(Air Supply+Vacuum Breaking)Combination(气控(供气+破坏真空)组合)
VD	Electric Control Vacuum Breaking(电控破坏真空)	ES	Energy-Saving(节能系统)
VQ	Pneumatic Control Vacuum Breaking(气控破坏真空)	-	NO(无)

TVMPL50-60

	Air Supply (供气)	Vacuum (真空)	Exhaust (排气)	Material (材料)
D	G1/4"	G1"	G1"	PPS
B	NPT1/4"	NPT1"	NPT1"	PPS
AD	G1/4"	G1"	G1"	Aluminum
E	NPT1/4"	NPT1"	NPT1"	Aluminum

TVMPL10-40

	Air Supply (供气)	Vacuum (真空)	Exhaust (排气)	Material (材料)
D	NPSF1/8"	G3/4"	G3/4"	PPS
B	NPSF1/8"	NPT3/4"	NPT3/4"	PPS
AD	G1/4"	G3/4"	G3/4"	Aluminum
E	NPT1/4"	NPT3/4"	NPT3/4"	Aluminum

# 多级真空发生器 Universal Pump

## TVMP10~60 Series

### Parameters(参数)

Model (型号)	-kPa	Air Supply Pressure (供气压力) bar	Air Consumption (空气消耗量) l/m	Max. Vacuum Level (最大真空度)	不同真空度(-kPa)的真空流量(l/min)										不同真空度(-kPa)的抽气时间(s/l)									
					0	10	20	30	40	50	60	70	80	90	10	20	30	40	50	60	70	80	90	
TVMP10	3.4	3.4	116 l/min	-92kPa	360	180	115	80	43	30	22.5	15.5	7.5	1.2	0.022	0.06	0.11	0.21	0.40	0.65	0.95	1.60	4	
TVMP20			230 l/min		600	320	250	135	75	60	46	30	13	1.5	0.014	0.031	0.06	0.10	0.20	0.34	0.50	0.80	2.5	
TVMP30			365 l/min		760	445	340	175	110	85	70	43	20	1.8	0.012	0.029	0.058	0.095	0.18	0.31	0.46	0.89	1.5	
TVMP40			445 l/min		850	550	430	280	145	115	85	60	28	2.2	0.010	0.025	0.043	0.075	0.11	0.19	0.27	0.45	1.2	
TVMP50			545 l/min		1150	760	530	350	180	148	115	78	34.5	3.5	0.006	0.015	0.029	0.052	0.085	0.145	0.202	0.33	1	
TVMP60			655 l/min		1200	830	550	360	215	170	130	90	36	5	0.005	0.013	0.027	0.045	0.070	0.105	0.23	0.46	0.90	
TVMP10	6	6	185 l/min	-89kPa	420	240	125	100	82	65	38	12.5	3.5	-	0.018	0.05	0.08	0.18	0.25	0.40	0.62	1.55	-	
TVMP20			370 l/min		700	510	290	195	160	115	70	22	8	-	0.01	0.022	0.048	0.08	0.11	0.20	0.35	0.78	-	
TVMP30			610 l/min		950	710	380	285	230	170	100	32	11	-	0.009	0.019	0.045	0.075	0.13	0.18	0.31	0.7	-	
TVMP40			720 l/min		1010	800	460	385	310	215	125	42	15.5	-	0.007	0.018	0.038	0.055	0.08	0.12	0.19	0.47	-	
TVMP50			780 l/min		1400	1120	560	490	355	260	150	50	25	-	0.005	0.013	0.026	0.045	0.062	0.115	0.194	0.56	-	
TVMP60			810 l/min		1500	1110	630	560	385	315	210	65	26	-	0.003	0.009	0.014	0.03	0.06	0.95	0.2	0.8	-	

### Dimensions(mm)(外形尺寸图(毫米))

#### TVMP10/20

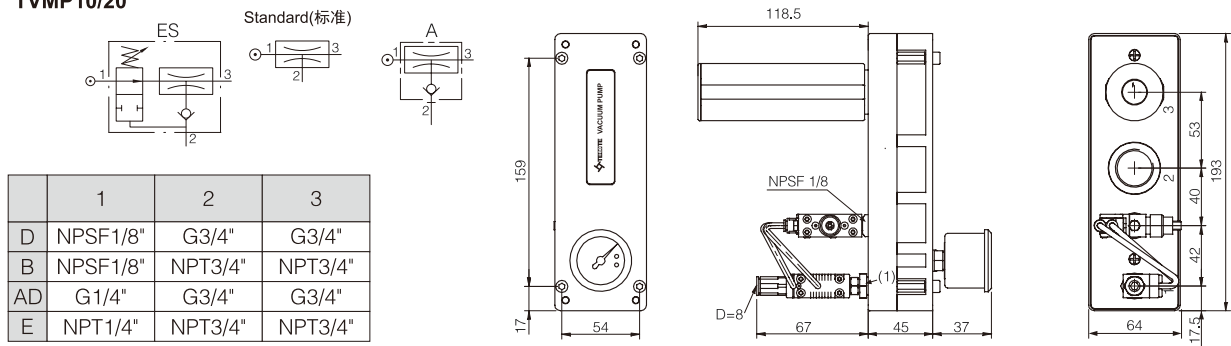

#### TVMP30/40

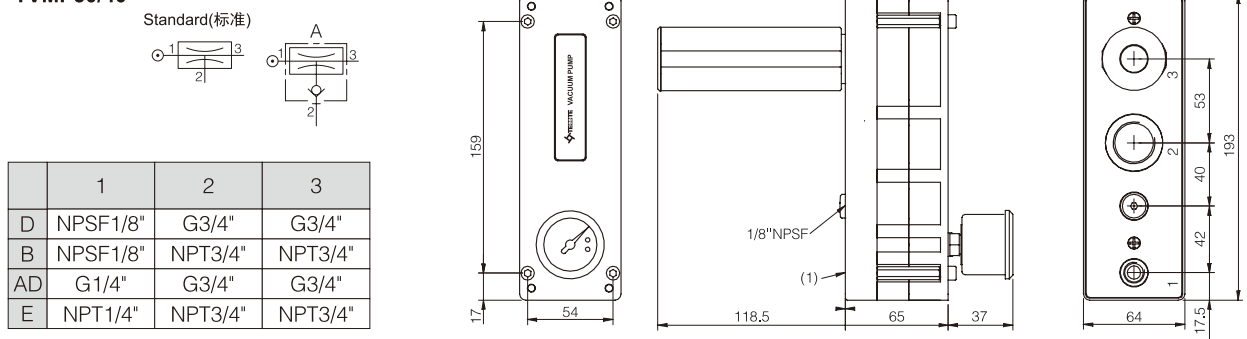

#### TVMP50/60

