

输送型真空发生器 Conveying Vacuum Pump

AIRBEST Series

ACP Series



Features(产品特点)

- This is an adjustable flow rate single stage vacuum pump. The design of this pump enables particles and small debris to pass directly through the pump.
- 这是一种可调节真空吸入流量的单级真空发生器，适用于颗粒状物体或小碎片吸入并排出。

Specifications(技术规格)

Max.vacuum Level(最大真空度)	-84kPa
Max.vacuum Flow Rate(最大真空流量)	3390l/m
Air Supply Pressure(供气压力)	4-6bar Max.7bar(最大7bar)
Air Supply Type(供气类型)	Dry Compressed Air(干燥的压缩空气)

How To Order(型号表示方法)

ACP 250 - AL

① ②

① Specification(规格)

250	500
375	750

② Material(材料)

AL-Aluminum(AL-铝)
SS-Stainless Steel(SS-不锈钢)

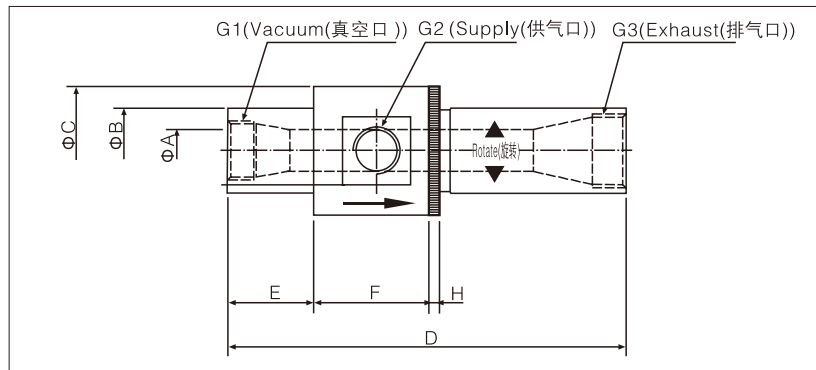

Model(型号)	Dimension(尺寸规格)									
	ΦA	ΦB	ΦC	D	E	F	H	G1	G2	G3
ACP250	6.5	19	32	94-105	22	32	5	G1/4	G1/8	G1/4
ACP375	10	25	45	155-165	38	45	5	G3/8	G3/8	G1/2
ACP500	13	32	51	155-160	38	51	5	G1/2	G3/8	G3/4
ACP750	19	38	58	175-189	38	51	5	G3/4	G1/2	G1

Model(型号)	Air Supply Pressure (供气压力) bar	ACP Series Air Consumption(L/m) At Different Vacuum Levels(-kPa)(ACP系列不同真空度(-kPa)的耗气量(L/m))				
		17	34	50	68	84
ACP250	5.5	112	169	233	276	342
ACP375		176	327	485	595	825
ACP500		340	625	795	940	1280
ACP750		650	875	1250	1790	2550

Model(型号)	ACP Series Air Consumption(L/m) At Different Vacuum Levels(-kPa)(ACP系列不同真空度(-kPa)的耗气量(L/m))				
	17	34	50	68	84
ACP250	280	240	200	162	125
ACP375	846	735	620	520	395
ACP500	1695	1325	1130	990	650
ACP750	3390	2460	1970	1440	1130