

输送型真空发生器 Conveying Vacuum Pump

AIRBEST Series

ACPS Series



Features(产品特点)

- Various models, suitable for different applications
- With straight vacuum passage, low vacuum level, high vacuum flow
- 尺寸型号齐全, 适合多种条件下的应用
- 采用直通结构, 低真空, 高流量

Applications(适用范围)

- Transport of porous materials such as foams, textiles, paper and so on
- Transport of granule materials such as powder, beans, rice, coffee bean and other bulk goods
- 用于输送透气性材料, 如泡沫、纺织品、纸张等
- 输送颗粒状物质, 如粉状物品、大豆、米粒、咖啡豆以及其他松散物体

Model(型号规格)

Model(型号)	Nozzle Diameter (mm)(内孔直径(毫米))	Material(材质)
ACPS100	10	AL – Aluminum Alloy (AL – 铝合金)
ACPS200	20	
ACPS400	40	
ACPS750	75	

Technical Parameters(性能参数)

Model(型号)	Max. vacuum Flow (最大真空流量) l/m (5bar)	Max. vacuum Level (最大真空度) -kPa	Operating Pressure (供气压力) bar	Air Consumption (空气消耗量)l/m (5bar)	Operating Temperature (工作温度) °C	Weight (重量) g
ACPS100	655	12	2~6	118	-20~80	76.5
ACPS200	1950	2~8		221		189
ACPS400	2900			430		522
ACPS750	8588			876		2308

Dimensions (mm)(外形尺寸(毫米))

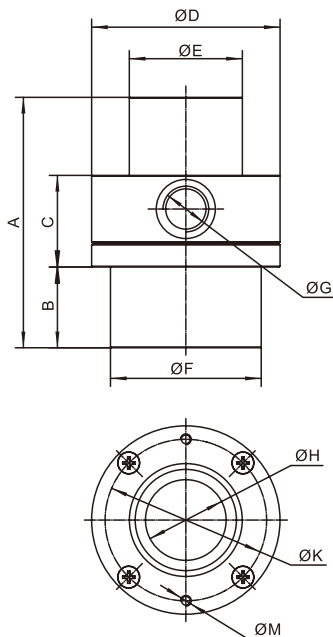

ACPS100~ACPS750

Model(型号)	A	B	C	D	E	F	G	H	K	M
ACPS100	70	23	21	37	19	19	G1/8	10	29	M4
ACPS200	90	30	30	50	32	38	G1/4	20	41.5	M4
ACPS400	96	35	35	84	52	75	G3/8	40	72	M4
ACPS750	180	35	65	140	100	125	G1/2	75	126	M6