

水份过滤器 Drain Separator

TAMG250~850 Series

图形符号

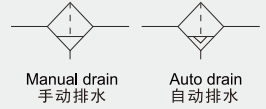

Common Specification (共同规格)

Model(型号)	TAMG
Fluid(流体)	Compressed Air(压缩空气)
Max. Operating Pressure(最高使用压力)	1.0Mpa
Min. Operating Pressure(最低使用压力)	0.15Mpa
Proof Pressure(保证耐压力)	1.5Mpa
Ambient&Fluid Temperature(环境和流体温度)	5~60°C
Filtration(水分去除率)	Eliminate Waterdrops Up To 99%
Element Life(滤芯寿命)	When pressure drop reaches at 0.1MPa

How To Order (型号表示方法)

TAMG 550 - 10

Body Size 规格
250,350,450, 550,650,850

Port Size 接管口径	250	350	450	550	650	850
02 Rc(PT)1/4	•					
03 Rc(PT)3/8	•	•				
04 Rc(PT)1/2		•				
06 Rc(PT)3/4			•	•		
10 Rc(PT)1				•		
14 Rc(PT)1 1/2					•	•
20 Rc(PT) 2						•

Accessory 附件
Nil(空) Without Bracket (Manual Drain)
B With Bracket(带支架)
D Auto Drain, One Touch Fitting(26mm)
Dn Auto drain, Nipple Rc(PT)1/8

Bowl 材质
Nil(空) PC Bowl
MeF Metal Bowl With Flat Type Sight Glass
MeP Metal Bowl With Pipe Type Sight Glass

Option 附件
Nil(空) None(无)
S Differential Pressure Indicator

Flow Characteristics(流量特性)

Initial Condition

Note: If compressed air is above max. flow, micro mist separator cannot operate well.

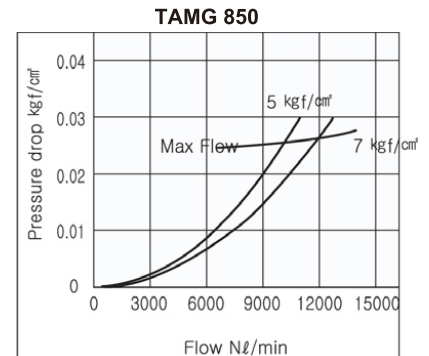
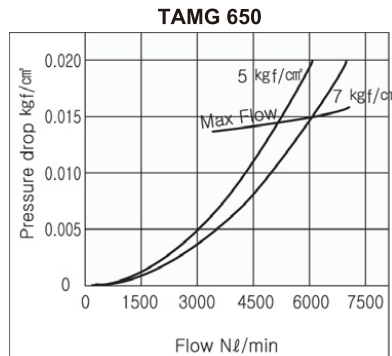
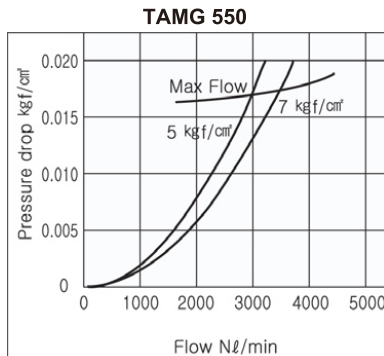
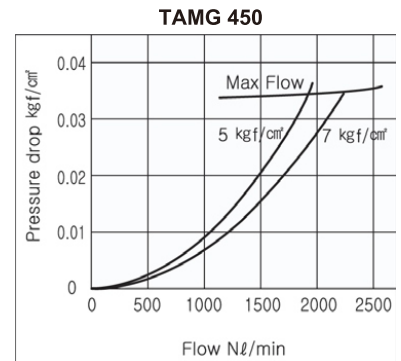
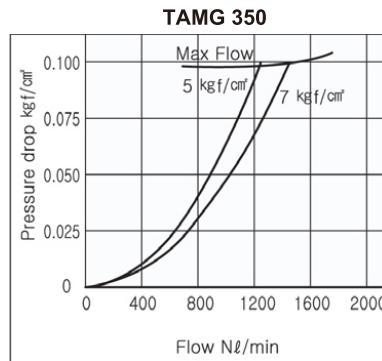
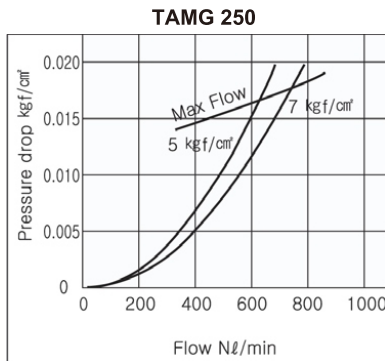

水份过滤器 Drain Separator

TAMG250~850 Series

Dimensions(mm)(外形尺寸图(毫米))

TAMG 250~850

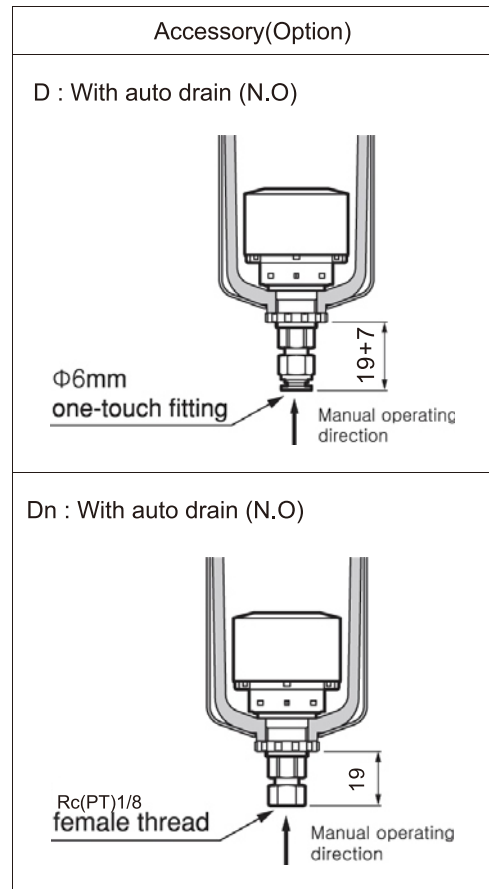
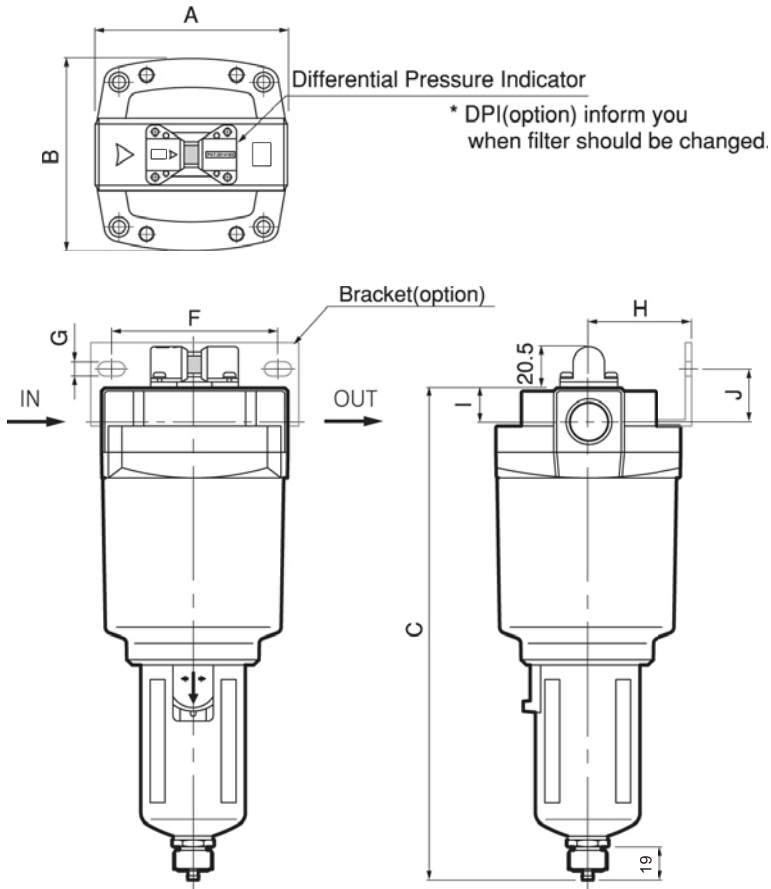

MeF: Metal bowl with flat type sight glass

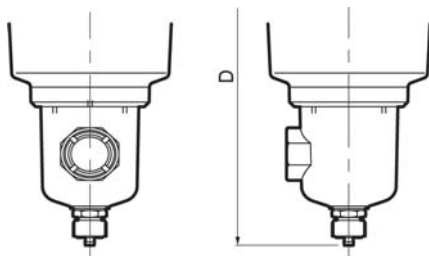

MeF type bowl not available for all 250 series.

MeP: Metal bowl with pipe type sight glass

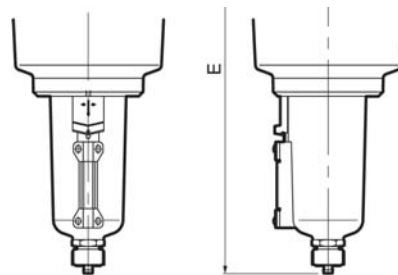

Model	Port size Rc(PT)	A	B	Height(Without auto drain)			F	G	H	I	J
				C	D(MeF)	E(MeP)					
TAMG 250	1/4	76	76	202	-	225	66	6	40	13	20
TAMG 350	3/8, 1/2	90	90	250	217	252	80	7	50	16	22
TAMG 450	3/4	106	106	283	250	285	90	9	55	19	25
TAMG 550	3/4, 1	122	122	320	287	322	100	9	65	22	30
TAMG 650	1 1/2	180	180	396	363	398	150	13	100	42	30
TAMG 850	1 1/2, 2	180	180	507	474	509	150	13	100	42	30