

拖链 Chain

RACER Series S015

How To Order (型号表示方法)

S015 -
 37R -
 B28 -
 D:1 -
 1430L -
 3SETS

Type 型号 Radius 弯曲半径 Width 幅 Divider 分割 Length 使用长度 Q'ty 订货量

Chain, Width, Brackets (轨条, 幅, 支架, 出气冒口)

- Pitch (mm): 15
- Bending Radius (mm): 37, 50, 75, 100
- 可能内幅 (mm) B: 20~100 (+8mm) (표준: 20, 28, 36, 44, 52, 60, 68, 76, 84, 92, 100)
- 内幅 높이 (mm): 19
- 전체외폭 (mm): B+10
- End Bracket 외폭 (mm): B+12
- 전체높이 (mm): H = 2R+28 (MIN)

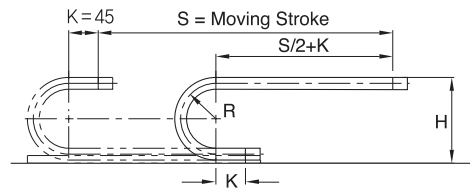
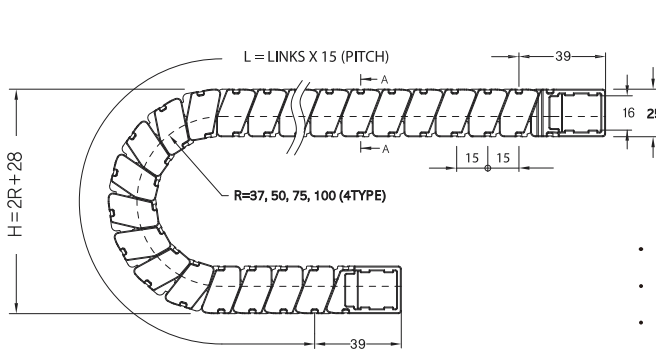

• Length (拖链长度) $L = S/2 + \pi R + 90$

• Radius (弯曲半径)

R	37	50	75	100
H	102	128	178	228

• Height (高度)

B	B+10
20	30
28	38
36	46
44	54
52	62
60	70

B	B+10
68	78
76	86
84	94
92	102
100	110

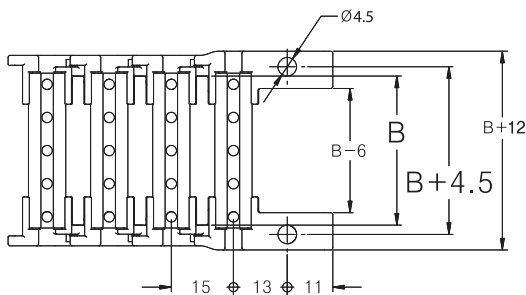
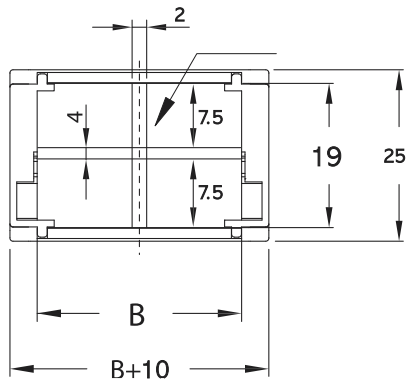

Fixed Bracket
固定端支架

Moving Bracket
移动端支架

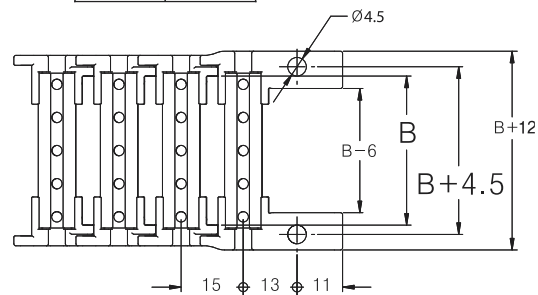

How To Order (型号表示方法)

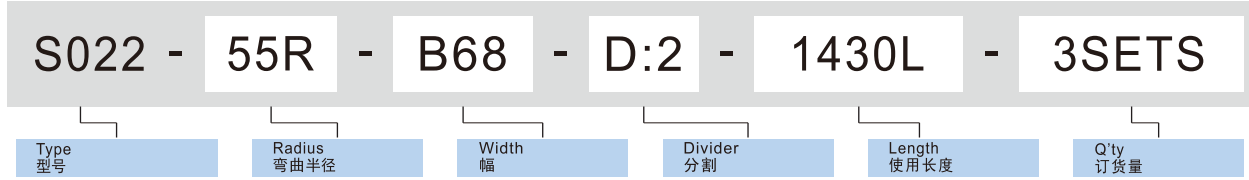

Chain, Width, Brackets, Strain Relief (轨条, 幅, 支架, 出气冒口)

- Pitch (mm): 22
- Bending Radius (mm): 55, 75, 90, 110 (4TYPE)
- 가능내폭 (mm) B: 36~140 (+8mm) (표준: 36, 44, 52, 60, 68, 76, 84, 92, 100, 108, 116, 124, 132, 140)
- 내측높이 (mm): 28
- 전체외폭 (mm): B+16
- End Bracket 외폭 (mm): B+20
- 전체높이 (mm): H = 2R+44 (MIN)

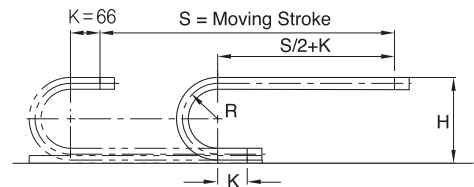
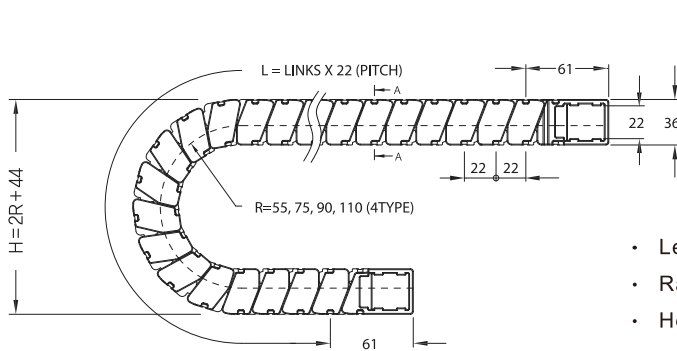

• Length (拖链长度) $L = S/2 + \pi R + 132$

• Radius (弯曲半径)

• Height (高度)

R	55	75	90	110
H	154	194	225	264

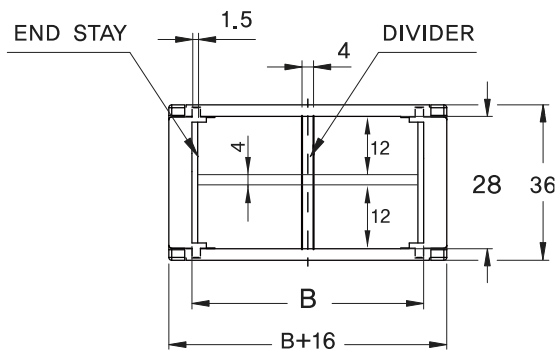

B	B+16	B	B+16
36	52	92	108
44	60	100	116
52	68	108	124
60	76	116	132
68	84	124	140
76	92	132	148
84	100	140	156

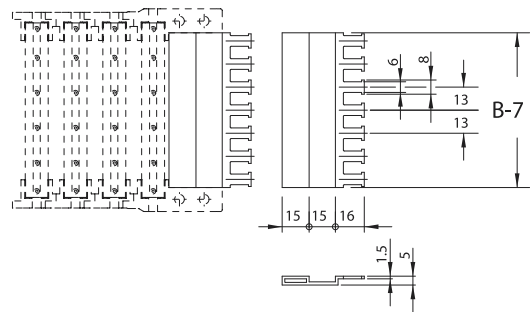
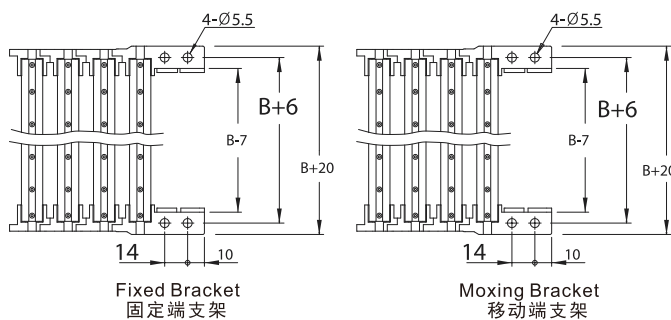

拖链 Chain

RACER Series S033

How To Order (型号表示方法)

S033 - 75R - B84 - D:3 - 1815L - 3SETS

Type
型号

Radius
弯曲半径

Width
幅

Divider
分割

Length
使用长度

Q'ty
订货量

Chain, Width, Brackets, Strain Relief (轨条, 幅, 支架, 出气冒口)

- Pitch (mm) : 33
- Bending Radius (mm) : 75, 90, 120, 150 (4TYPE)
- 가능내폭 (mm) B : 36~140 (+8mm) (표준 : 36, 44, 52, 60, 68, 76, 84, 92, 100, 108, 116, 124, 132, 140)
- 내측높이 (mm) : 42
- 전체외폭 (mm) : B+16
- End Bracket 외폭 (mm) : B+20
- 전체높이 (mm) : H = 2R+60 (MIN)

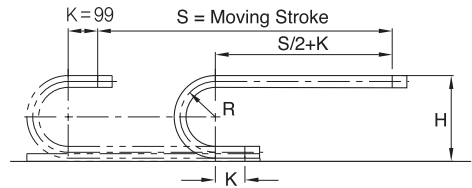
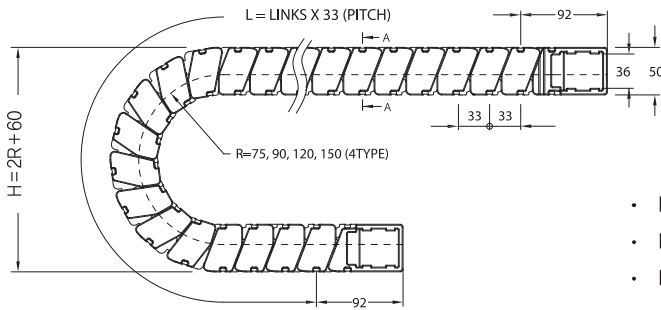

• Length(拖链长度) $L = S/2 + \pi R + 198$

• Radius(弯曲半径)

R	75	90	120	150
H	210	240	300	360

• Height(高度)

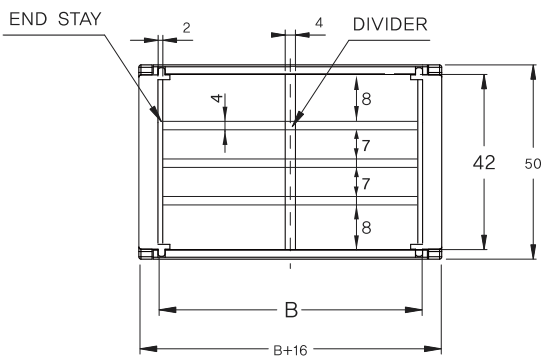

B	B+16
36	52
44	60
52	68
60	76
68	84
76	92
84	100

B	B+16
92	108
100	116
108	124
116	132
124	140
132	148
140	156

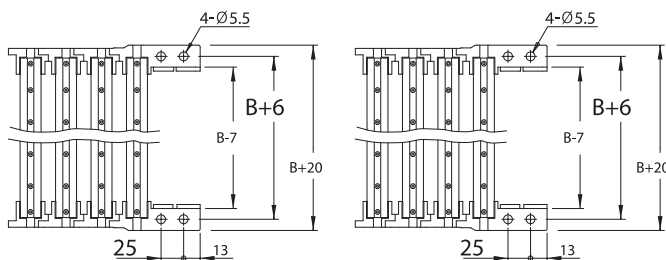

Fixed Bracket
固定端支架

Moving Bracket
移动端支架

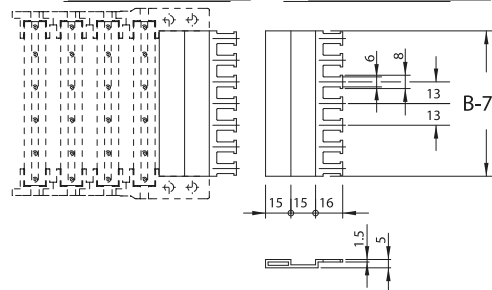

How To Order (型号表示方法)

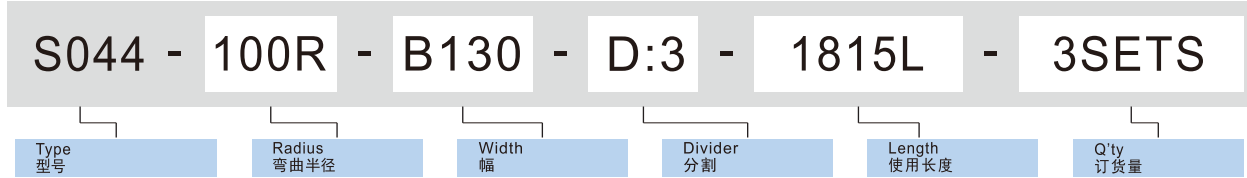

Chain, Width, Brackets, Strain Relief (轨条, 幅, 支架, 出气冒口)

- Pitch (mm): 44
- Bending Radius (mm): 100, 120, 150, 200 (4TYPE)
- 가능내폭 (mm) B: 100~295 (+15mm) (표준: 100, 115, 130, 145, 160, 175, 190, 205, 220, 235, 250, 265, 280, 295)
- 내측높이 (mm): 63
- 전체외폭 (mm): B+35
- End Bracket 외폭 (mm): B+30
- 전체높이 (mm): H = 2R+88 (MIN)

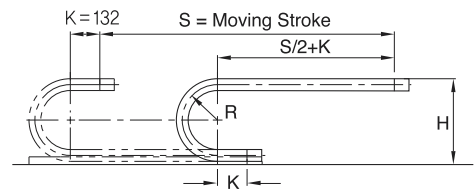
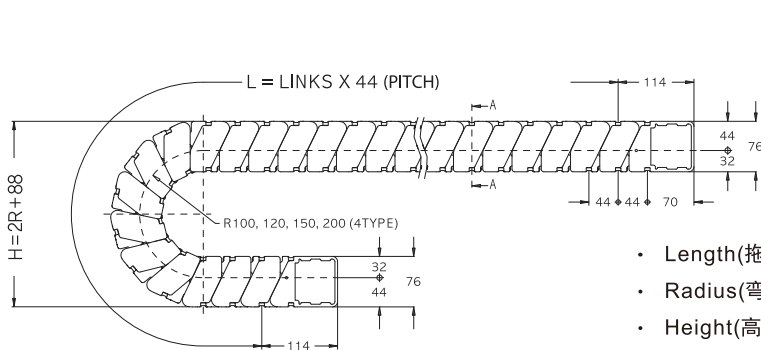

• Length (拖链长度) $L = S/2 + \pi R + 264$

• Radius (弯曲半径)

• Height (高度)

R	100	120	150	200
H	288	328	388	488

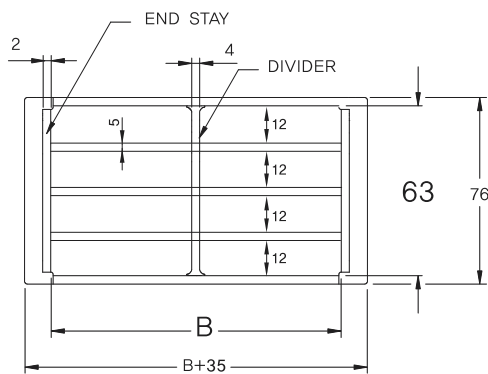

B	B+35
100	135
115	150
130	165
145	180
160	195
175	210
190	215

B	B+35
205	240
220	255
235	270
250	285
265	300
280	315
295	330

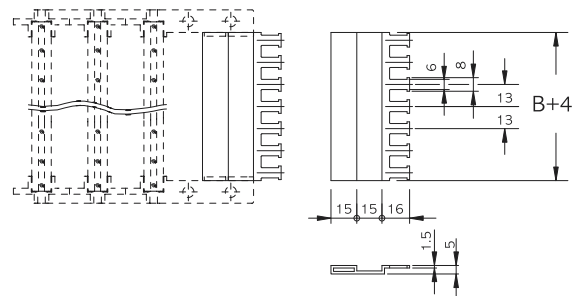
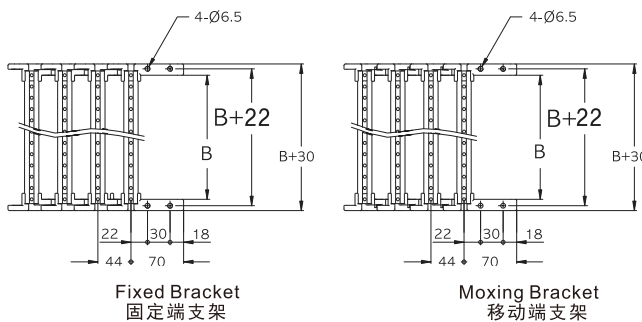

拖链 Chain

RACER Series S055

How To Order (型号表示方法)

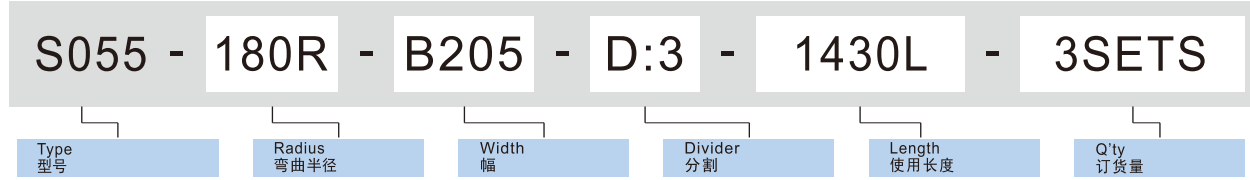

Chain, Width, Brackets, Strain Relief (轨条, 幅, 支架, 出气冒口)

- Pitch (mm) : 55
- Bending Radius (mm) : 150, 180, 200, 250, 300 (5TYPE)
- 가능내폭 (mm) B : 100~295 (+15mm) (표준 : 100, 115, 130, 145, 160, 175, 190, 205, 220, 235, 250, 265, 280, 295)
- 내측높이 (mm) : 82
- 전체외폭 (mm) : B+41
- End Bracket 외폭 (mm) : B+41
- 전체높이 (mm) : H = 2R+110 (MIN)

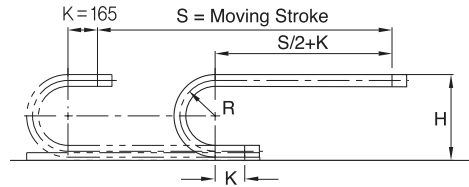
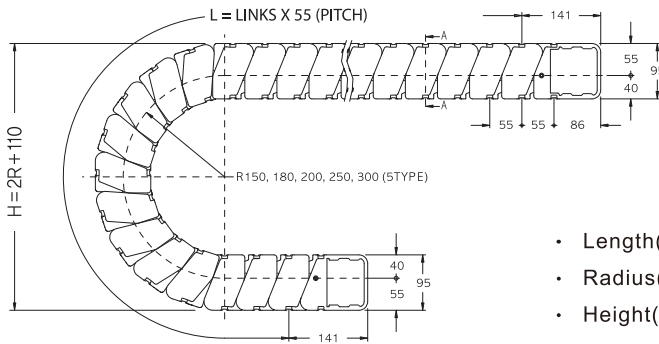

- Length(拖链长度) $L = S/2 + \pi R + 330$
- Radius(弯曲半径)
- Height(高度)

R	150	180	200	250	300
H	410	470	510	610	710

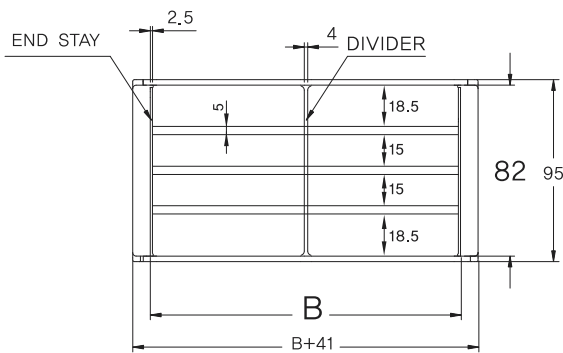

B	B+41
100	141
115	156
130	171
145	186
160	201
175	216
190	231

B	B+41
205	246
220	261
235	276
250	291
265	306
280	321
295	336

